

SERIES F4 ¼ DIN RAMPING CONTROLLERS

Ramping Control Programming Made Easy Through Advanced Technology

The SERIES F4 ¼ DIN industrial ramping controllers offer an easy to set up and operate solution for the most demanding ramp and soak processing applications. The features and performance of these units make them ideally suited for environmental chamber or furnace and oven applications. Single and dual channel versions are available.

These competitively-priced controllers feature a four line, high-definition LCD interface display that makes profile programming and controller configuration significantly faster and easier. A 16-bit microprocessor supports all the accuracy and performance advantages you have come to expect from a Watlow® controller.

Up to 256 steps can be programmed into as many as 40 nameable profiles. Profiles can be programmed to wait for events or for up to three different process variables. A guaranteed soak feature allows you to set how closely your process needs to be controlled.

The four digital event inputs can be programmed to remotely start, pause or terminate any of your preprogrammed process recipes. The eight event outputs are segment programmable, or three of them can be assigned to a programmable compressor and boost heat/boost cool control. A real-time clock can be used to start a profile at any time.

Serial communication and dual alarm relays are included in the base unit. The SERIES F4 ramping controllers are packaged with a NEMA 4X front face to withstand harsh environments and a 4 in. (101.6 mm) deep case with removable connectors for wiring convenience.

The SERIES F4 controllers are manufactured by Watlow, ISO 9001 registered and backed by a three-year warranty.



Features and Benefits

Guided 256 step, 40 profile ramp and soak programmable memory

- Supports a wide range of processing applications

High-definition, four line LCD controller interface display

- Simplifies setup and operation

Menu customization

- Offers enhanced process monitoring

High-performance, 16-bit microprocessor

- Precise process control

Universal inputs

- Provides application versatility

Expandable modular construction

- Field upgradable

Enhanced environmental chamber control

- Supports humidity, compressor, boost heat/boost cool control

Cascade control

- Provides precise two variable control

Real-time clock with battery backup

- Offers operational flexibility



ISO 9001



Registered Company
Winona, Minnesota USA

WIN-F4R-0908

Set Point Ramp and Soak Programming

The enhanced programming features found in the SERIES F4 ramping controllers are the result of listening to our customers' demand for greater capabilities with reduced programming complexity.

A profile guide leads the programmer through the programming process by offering choices for step configuration. For better operator recognition, profiles and digital I/O used for events can be given names of up to 10 characters in length.

Five step types including ramp, soak, jump, auto start and end offer the programmer complete flexibility.

Ramp steps can be based on time or rate. Ramp and soak steps can be programmed to wait for up to four event inputs and three process variables. Up to eight event outputs are step selectable. Since your thermal systems characteristics may change over the operating range, up to 10 sets of PID heat/cool parameters are step selectable. The auto start step can start a profile based on a set date, a day of the week or daily, the choice is yours. The jump step can be used to jump within a profile or to another profile. The end step terminates a program with the control outputs programmed to your process needs.

Temperature and Humidity Chamber Application

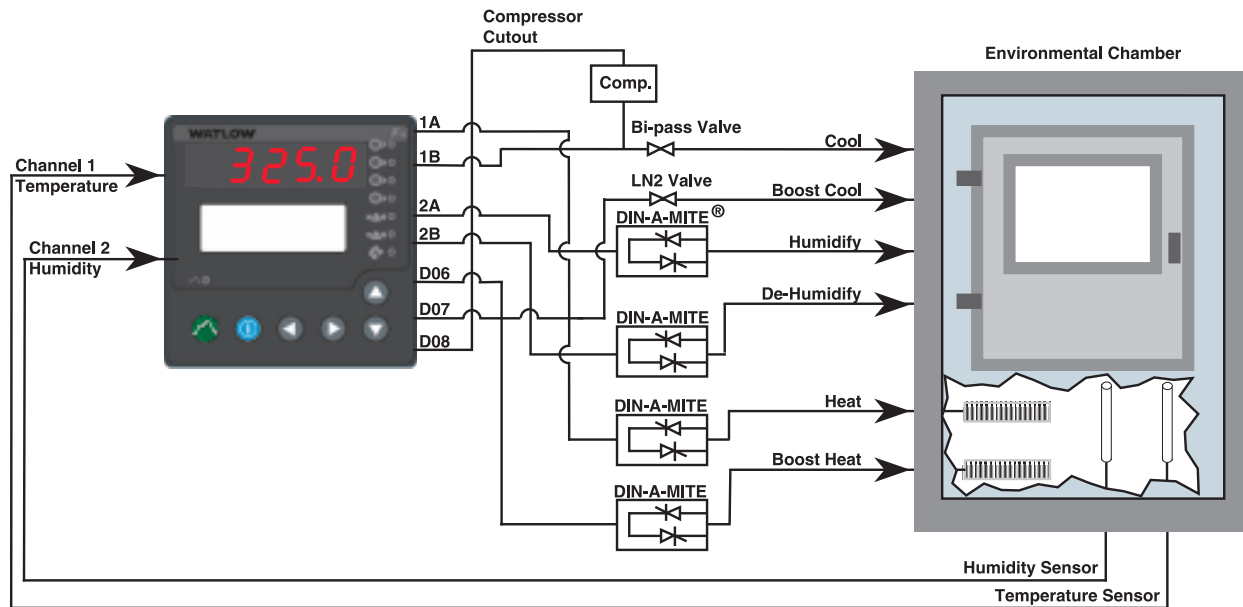

Serial Communication

EIA-232 and EIA-485 serial communication interfaces are included in the base unit of both the SERIES F4S (single channel) and the SERIES F4D (dual channel) controllers. The baud rate is selectable as either 9600 or 19200 Kbaud. The protocol is Modbus®.

Alarms

Two Form "C" electromechanical alarm relays are included in the base units. These alarms can be programmed as either process or deviation alarms. The alarms can be tied to up to three process variables.

Optional Retransmit

Optional retransmit capability is available to retransmit one or two variables. These variables include up to three process variables, control set points or percent load power.

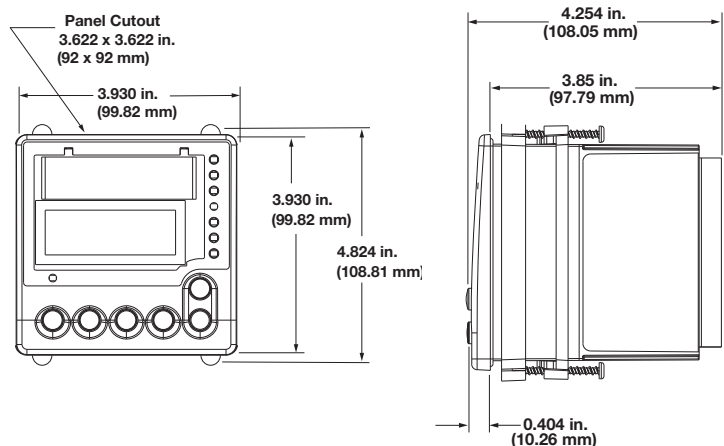

Specifications

Dimensions

- Width x height x depth
3.93 in. x 3.93 in. x 3.85 in. (99 mm x 99 mm x 97 mm)
panel mount

Specifications

Universal Analog Inputs 1 (2 and 3 Optional)

- Updates rates, IN1 = 20Hz, IN2 and IN3 = 10Hz

Thermocouple

- Type J, K, T, N, E, C (W5), D (W3), PTII, R, S, B
- Input impedance 20M Ω

RTD

- 2- or 3-wire platinum, 100, 500 or 1000 Ω
- JIS or DIN curves, 1.0 or 0.1 indication

Process

- Input resolution \approx 50,000 bits at full scale
- Range selectable: 0-10V \approx (dc), 0-5V \approx (dc), 1-5V \approx (dc), 0-50mV, 0-20mA, 4-20mA
- Voltage input impedance 20K Ω
- Current input impedance 100 Ω

Digital Inputs (4)

- Update rate = 10Hz
- Contact or dc voltage (36V \approx (dc) max.)
- 10K Ω input impedance

Control Outputs (1A, 1B, 2A, 2B)

- Update rate = 20Hz

Open Collector/Switched dc

- Internal load switching (nominal):
Switched dc, 22 to 28V \approx (dc), limited @ 30mA
- External load switching (max.):
Open collector 42V \approx (dc) @ 0.5A

Solid State Relay

- Zero switched, optically coupled, 0.5A @
24V \sim (ac) min., 253V \sim (ac) max.

Process Outputs (Optional Retransmit)

- Update rate = 1Hz
- User selectable 0-10V \approx (dc), 0-5V \approx (dc), 1-5V \approx (dc) @
1K Ω min., 0-20mA, 4-20mA @ 800 Ω max.
- Resolution:
dc ranges = 2.5mV nominal
mA ranges = 5 μ A nominal
- Calibration accuracy:
dc ranges = \pm 15mV
mA ranges = \pm 30 μ A
- Temperature stability 100ppm/ $^{\circ}$ C

Alarm Outputs

- Output update rate 1Hz
- Electromechanical relay, Form C, 2A @
30V \approx (dc) or 240V \sim (ac) max.

Digital Outputs (8)

- Update rate = 10Hz
- Open collector output
- Off = 42V \approx (dc) max @ 10 μ A
- On = 0.2V \approx (dc) max @ 50mA sink
- Internal supply: 5V \approx (dc), @ 80mA

Communications

EIA-232 and EIA-485 serial communications
with Modbus[®] RTU protocol

Safety and Agency Approvals

- UL[®]/C-UL[®] 916 listed, File #E185611

Process Control Equipment

- CE
 - EN 61010-1
 - EN 61326
 - IP65 and NEMA 4X

Terminals

- Touch-safe, removable terminal blocks, accepts
12 to 22 gauge wire

Power

- 100-240V \sim (ac), -15%, +10%; 50/60Hz, \pm 5%
- 24-28V \approx (ac/dc), -15%, +10% (order option)
- 39VA max. power consumption
- Data retention upon power failure via nonvolatile
memory (7 years for battery backed RAM)
- Sensor input isolation from input to input to output to
communication circuitry is 500V \sim (ac)

Operating Environment

- 32 to 130 $^{\circ}$ F (0 to 55 $^{\circ}$ C)
- 0 to 90% RH, non-condensing
- Storage temperature: -40 to 158 $^{\circ}$ F (-40 to 70 $^{\circ}$ C)

Accuracy

- Calibration accuracy and sensor conformity:
 \pm 0.1% of span \pm 1 $^{\circ}$ C @ 77 $^{\circ}$ F \pm 5 $^{\circ}$ F (25 $^{\circ}$ C \pm 3 $^{\circ}$ C) ambient
and rated line voltage \pm 10% with the following
exceptions:
Type T: 0.12% of span for -328 to -58 $^{\circ}$ F (-200 to -50 $^{\circ}$ C)
Types R and S: 0.15% of span for 32 to 212 $^{\circ}$ F
(0 to 100 $^{\circ}$ C)
Type B: 0.24% of span for 1598 to 3092 $^{\circ}$ F
(870 to 1700 $^{\circ}$ C)
- Accuracy span: Less than or equal to operating ranges,
1000 $^{\circ}$ F (540 $^{\circ}$ C) min.
- Temperature stability: \pm 0.1 $^{\circ}$ F/ $^{\circ}$ F (\pm 0.1 $^{\circ}$ C/ $^{\circ}$ C) rise in
ambient for thermocouples
 \pm 0.05 $^{\circ}$ F/ $^{\circ}$ F (\pm 0.05 $^{\circ}$ C/ $^{\circ}$ C) rise in ambient for RTD
sensors

Displays

- Process: 5, 7 segment LED red
- Control interface display: high definition LCD green

Sensor Operating Ranges:

Type J:	32	to	1500 $^{\circ}$ F	or	0	to	815 $^{\circ}$ C
Type K:	-328	to	2500 $^{\circ}$ F	or	-200	to	1370 $^{\circ}$ C
Type T:	-328	to	750 $^{\circ}$ F	or	-200	to	400 $^{\circ}$ C
Type N:	32	to	2372 $^{\circ}$ F	or	0	to	1300 $^{\circ}$ C
Type E:	-32	to	1470 $^{\circ}$ F	or	-200	to	800 $^{\circ}$ C
Type C: (W5)	32	to	4200 $^{\circ}$ F	or	0	to	2315 $^{\circ}$ C
Type D: (W3)	32	to	4352 $^{\circ}$ F	or	0	to	2400 $^{\circ}$ C
Type PTII:	32	to	2543 $^{\circ}$ F	or	0	to	1395 $^{\circ}$ C
Type R:	32	to	3200 $^{\circ}$ F	or	0	to	1760 $^{\circ}$ C
Type S:	32	to	3200 $^{\circ}$ F	or	0	to	1760 $^{\circ}$ C
Type B:	32	to	3300 $^{\circ}$ F	or	0	to	1816 $^{\circ}$ C
RTD (DIN):	-328	to	1472 $^{\circ}$ F	or	-200	to	800 $^{\circ}$ C
RTD (JIS):	-328	to	1166 $^{\circ}$ F	or	-200	to	800 $^{\circ}$ C
Process:	-19,999	to	30,000	units			

Sensor Accuracy Ranges:

Input ranges

Type J:	32	to	1382 $^{\circ}$ F	or	0	to	750 $^{\circ}$ C
Type K:	-328	to	2282 $^{\circ}$ F	or	-200	to	1250 $^{\circ}$ C
Type T:	-328	to	662 $^{\circ}$ F	or	-200	to	350 $^{\circ}$ C
Type N:	32	to	2282 $^{\circ}$ F	or	0	to	1250 $^{\circ}$ C
Type E:	-328	to	1470 $^{\circ}$ F	or	-200	to	800 $^{\circ}$ C
Type C(W5):	32	to	4200 $^{\circ}$ F	or	0	to	2315 $^{\circ}$ C
Type D(W3):	32	to	4352 $^{\circ}$ F	or	0	to	2400 $^{\circ}$ C
Type PTII:	32	to	2540 $^{\circ}$ F	or	0	to	1393 $^{\circ}$ C
Type R:	32	to	2642 $^{\circ}$ F	or	0	to	1450 $^{\circ}$ C
Type S:	32	to	2642 $^{\circ}$ F	or	0	to	1450 $^{\circ}$ C
Type B:	1598	to	3092 $^{\circ}$ F	or	870	to	1700 $^{\circ}$ C
RTD (DIN):	-328	to	1472 $^{\circ}$ F	or	-200	to	800 $^{\circ}$ C
RTD (JIS):	-328	to	1166 $^{\circ}$ F	or	-200	to	630 $^{\circ}$ C
Process:	-19,999	to	30,000	units			

Note: Specifications subject to change without notice.

Ordering Information

¼ DIN Single Channel Ramping Controller

SERIES F4

¼ DIN, Single Channel Ramping Controller

F4 S - A -

Single Channel Ramping Controller

1 universal analog input, 4-digital inputs, 8-digital outputs, 2 alarms, EIA-232/485 comms

Power Supply

H = 100-240V \approx (ac/dc)

L = 24-28V \approx (ac/dc)

Output 1A

C = Open collector/switched dc

F = Process, 0-5, 1-5, 0-10V \approx (dc), 0-20mA, 4-20mA

K = Solid state Form A 0.5A relay

Output 1B

A = None

C = Open collector/switched dc

F = Process, 0-5, 1-5, 0-10V \approx (dc), 0-20mA, 4-20mA

K = Solid state Form A 0.5A relay

Auxiliary Input Module

0 = None

6 = Dual universal inputs

Auxiliary Retransmit Module

0 = None

1 = Single retransmit output

0-5, 1-5, 0-10V \approx (dc), 0-20mA, 4-20mA

2 = Dual retransmit outputs

0-5, 1-5, 0-10V \approx (dc), 0-20mA, 4-20mA

Language and RTD Option

1 = English with 100 Ω RTD

2 = German with 100 Ω RTD

3 = French with 100 Ω RTD

4 = Spanish with 100 Ω RTD

5 = English with 500 and 1K Ω RTD

6 = German with 500 and 1K Ω RTD

7 = French with 500 and 1K Ω RTD

8 = Spanish with 500 and 1K Ω RTD

Display and Custom Options

RG = Standard display (Red/Green display only)

XX = Custom options: software, setting parameters, overlay

Your Authorized Watlow Distributor is:

Ordering Information

¼ DIN Dual Channel Ramping Controller

SERIES F4

¼ DIN, Dual Channel Ramping Controller

F4 D - -

Dual Channel Ramping Controller

3 universal analog inputs, 4-digital inputs, 8-digital outputs, 2 alarms, EIA-232/485 comms

Power Supply

H = 100-240V \approx (ac/dc)

L = 24-28V \approx (ac/dc)

Output 1A

C = Open collector/switched dc

F = Process, 0-5, 1-5, 0-10V \approx (dc), 0-20mA, 4-20mA

K = Solid state Form A 0.5A relay

Output 1B

A = None

C = Open collector/switched dc

F = Process, 0-5, 1-5, 0-10V \approx (dc), 0-20mA, 4-20mA

K = Solid state Form A 0.5A relay

Output 2 A

C = Open collector/switched dc

F = Process, 0-5, 1-5, 0-10V \approx (dc), 0-20mA, 4-20mA

K = Solid state Form A 0.5A relay

Output 2 B

A = None

C = Open collector/switched dc

F = Process, 0-5, 1-5, 0-10V \approx (dc), 0-20mA, 4-20mA

K = Solid state Form A 0.5A relay

Auxiliary Retransmit Module

0 = None

1 = Single retransmit output 0-5, 1-5, 0-10V \approx (dc), 0-20mA, 4-20mA

2 = Dual retransmit outputs 0-5, 1-5, 0-10V \approx (dc), 0-20mA, 4-20mA

Language and RTD Option

1 = English with 100 Ω RTD

2 = German with 100 Ω RTD

3 = French with 100 Ω RTD

4 = Spanish with 100 Ω RTD

5 = English with 500 and 1K Ω RTD

6 = German with 500 and 1K Ω RTD

7 = French with 500 and 1K Ω RTD

8 = Spanish with 500 and 1K Ω RTD

Display and Custom Options

RG = Standard display (Red/Green display only)

XX = Custom options: software, setting parameters, overlay

To be automatically connected to the nearest North American Technical Sales Office:

1-800-WATLOW2 • www.watlow.com • info@watlow.com

International Technical Sales Offices: Australia, +61-3-9335-6449 • China, +86-21-6106-1425 • France, +33 1 3073-2425 • Germany, +49 (0) 7253-9400-0 • Italy, +39 (0) 2 458-8841 • Japan, +81-3-3518-6630 • Korea, +82-2-2628-5770 • Malaysia, +60-3-8076-8741 • Mexico, +52 (442) 217-6235 • Singapore, +65-6773-9488 • Spain, +34 91 675 1292 • Sweden, +46 35-27-1166 • Taiwan, +886-7-288-5168 • United Kingdom, +44 (0) 115-964-0777